

ASSEMBLY INSTRUCTION  
SHIELDS OFFICE CHAIR  
ITEM CODE 84111

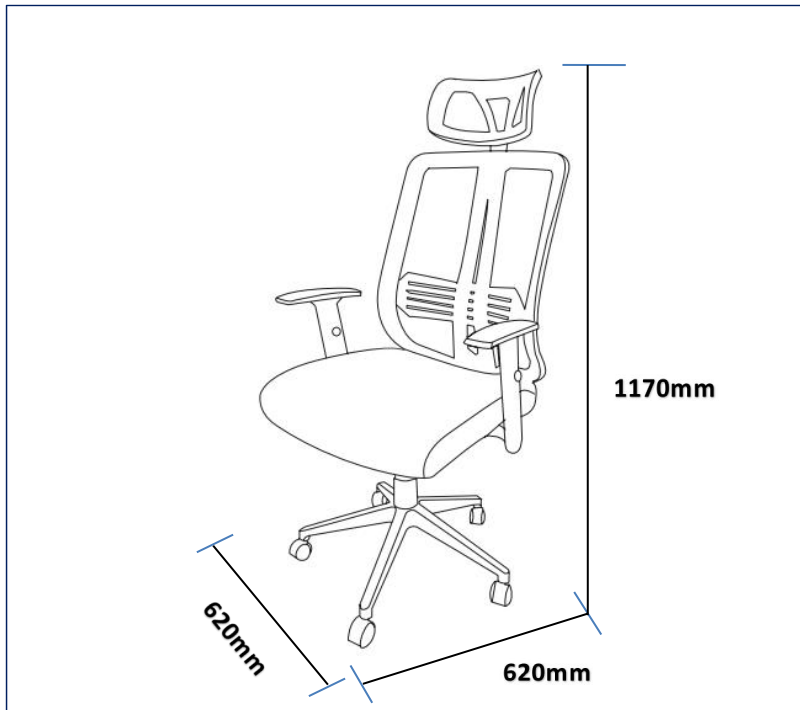

Imported by JWA Furniture Pty Ltd, Qld, Brisbane Australia.  
For any assistance with assembly or for missing parts please refer to your receipt

## PRE-ASSEMBLY PREPARATION

### Before you start:



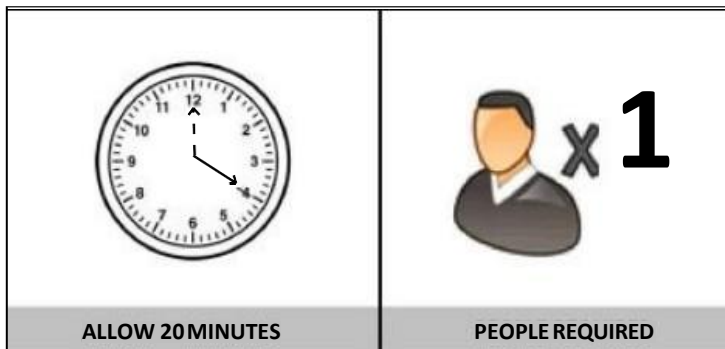



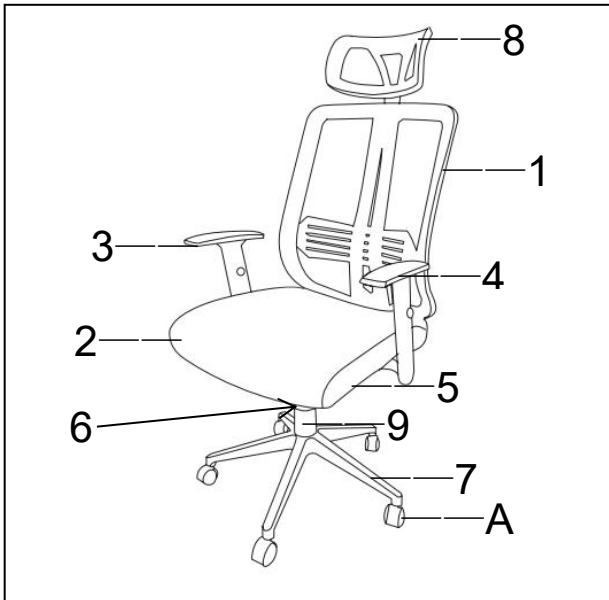





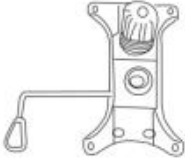

1. Choose a clean, level, spacious assembly area. Avoid hard surfaces that may damage the product
2. Take care when lifting. Product should be assembled as near as possible to the point of use
3. Ensure that you have all required contents for complete assembly
4. Always read the assembly instructions carefully before beginning assembly.
5. Keep all hardware parts and packaging out of reach of small children.
6. Do not over tighten the screws and bolts as this may damage the threads



# PARTS LIST



1	BACKREST
2	SEAT CUSHION
3	RIGHT ARMREST
4	LEFT ARMREST
5	MECHANISM
6	GASLIFT
7	BASE
8	HEAD PILLOW
9	DUST COVER
A	CASTOR

 <p>1-1pc 69*50*16CM</p>	 <p>2-1pc 52*52*6.5CM</p>	 <p>3-1pc 423*29*7M</p>	 <p>4-1pc 23*29*7CM</p>	 <p>5-1pc 28*18*0.2CM</p>
 <p>6-1pc Φ 5*4.3*26CM</p>	 <p>7-1pc 350 #</p>	 <p>8-1pc 28*28*15CM</p>	 <p>9-1pc Φ 7*10CM</p>	 <p>A*5pcs Φ 50MM</p>
 <p>B*4 M6*16</p>	 <p>C*4 M6*35</p>	 <p>D*8 M6*30</p>	 <p>E*14 Φ 6*16*1.2MM</p>	 <p>F*1 3*7CM</p>

**STEP 1:** Push castors A into piece in part 7. Turn and apply pressure at the same time to each castor until it slots into place.

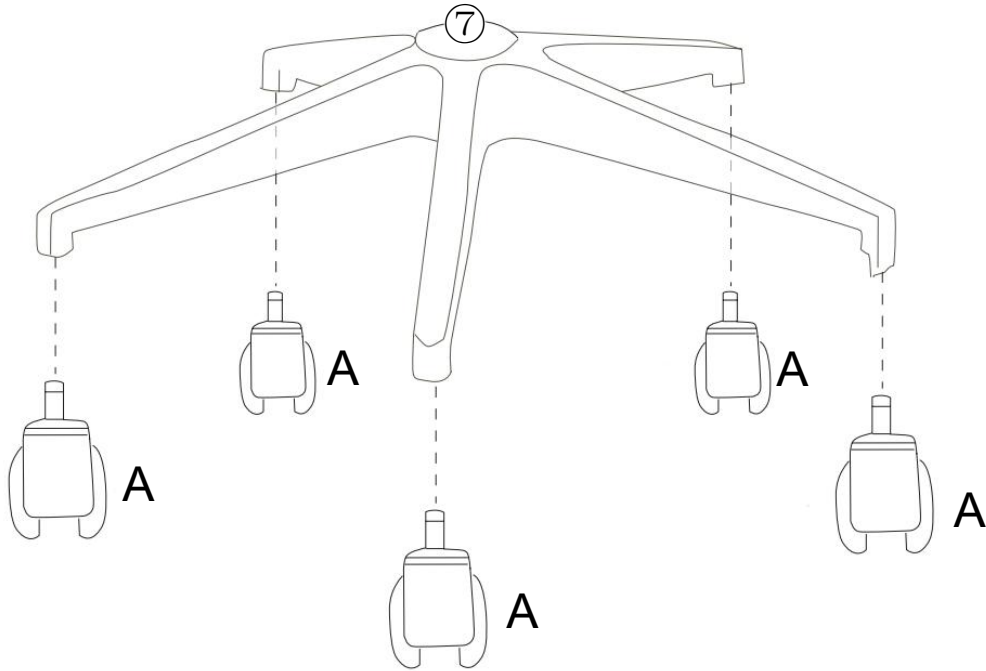

**STEP 2:** Attach part 6 to part 7. Ensure part 6 is secure and unable to be removed easily. Place part 9 on to part 6, as shown.

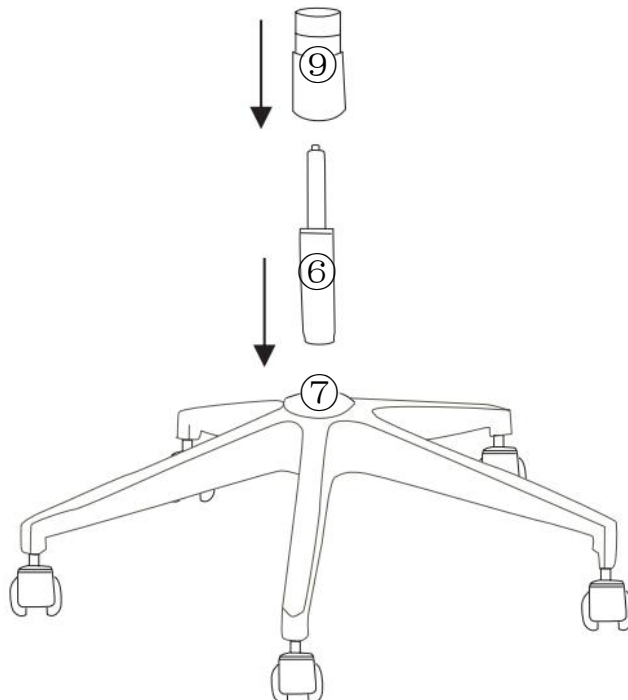

**STEP 3:** Fix part 1 to part 2 using bolts C, washers E and tighten with allen key F. **Please note: Do not fully tighten bolts C until you complete step 4.**

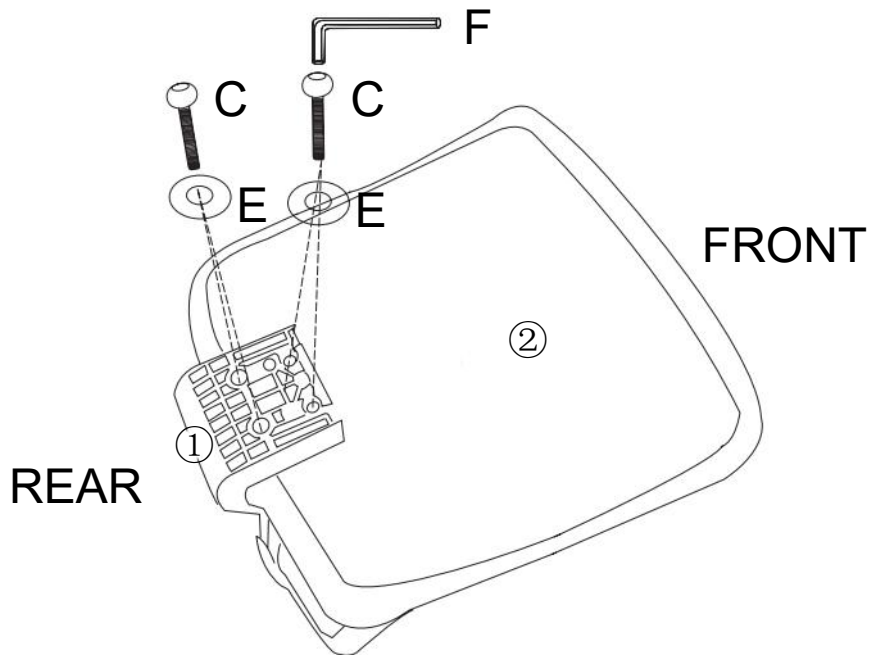

**STEP 4:** Fix part 5 to part 2 using bolts B, washers E and tighten with allen key F. **Please note: You may now fully tighten bolts C from previous step.**

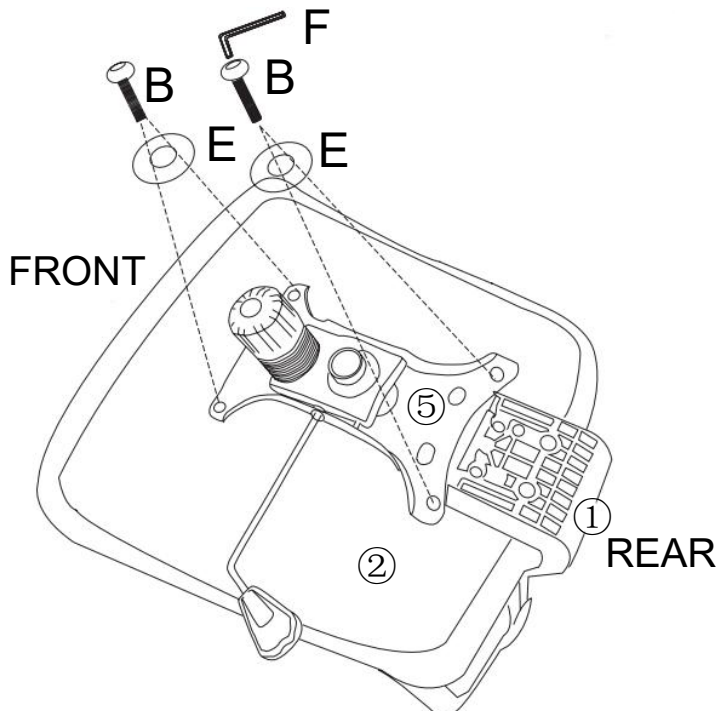

**STEP 5:** Fix left armrest 3 and right armrest 4 to part 2 using bolts D, washers E and tighten with allen key F.

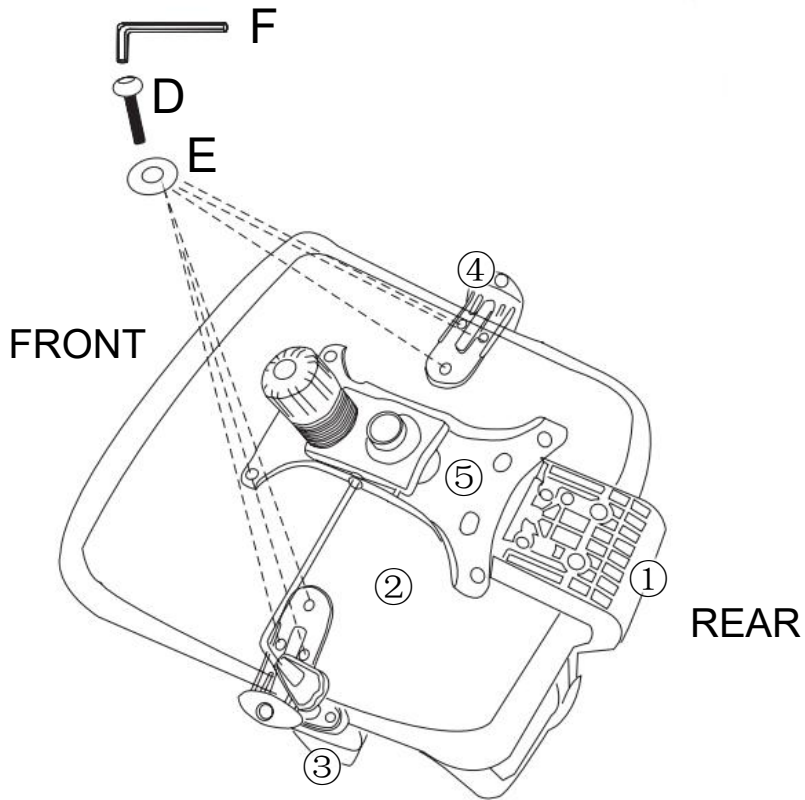

**STEP 6:** Fix part 8 to assembled unit using bolts D and tighten with allen key F, as shown.

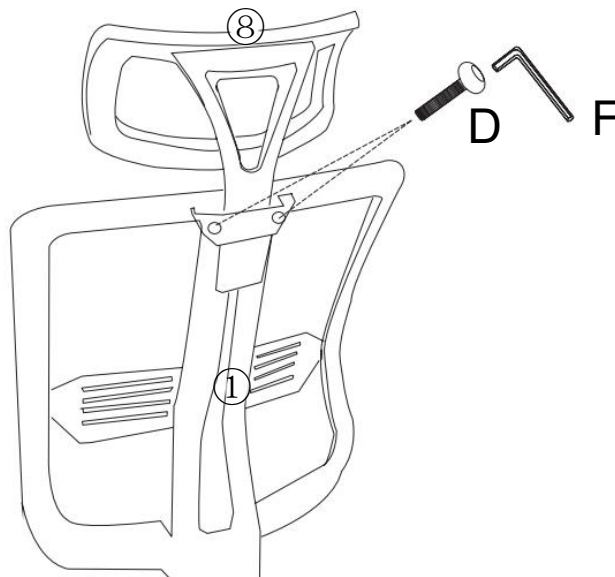

**STEP 7:** Fix assembled chair seat to base. You may need to carefully sit on the assembled office chair to use your weight to lock the gas lift fully into place.

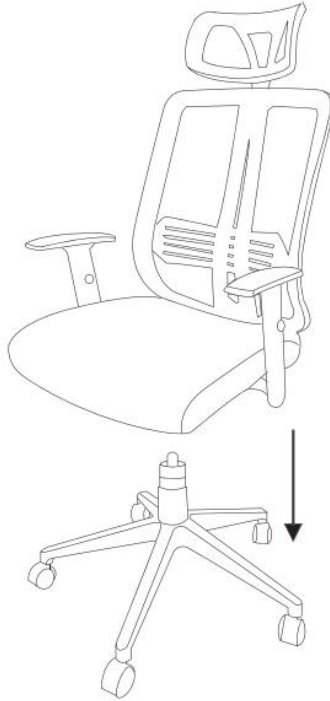

**STEP 8:** Height Adjustment Instructions: To lower the height of the chair, sit in chair and pull lever upwards. To increase height of chair, remove yourself from chair and pull the lever upwards. Tilt Adjustment Instructions: Sit in the chair and pull the lever outwards to use the tilt function.

If you do not wish to use the tilt function push the lever inwards to lock the chair into place. **Please note: do not apply any pressure to the backrest when adjusting the tilt function.** Headrest Adjustment Instructions: To raise the headrest, use both hands to pull the headrest up until it clicks into your desired height. To lower the headrest, use both hands to push the headrest down until it clicks into your desired height. Armrest Adjustment

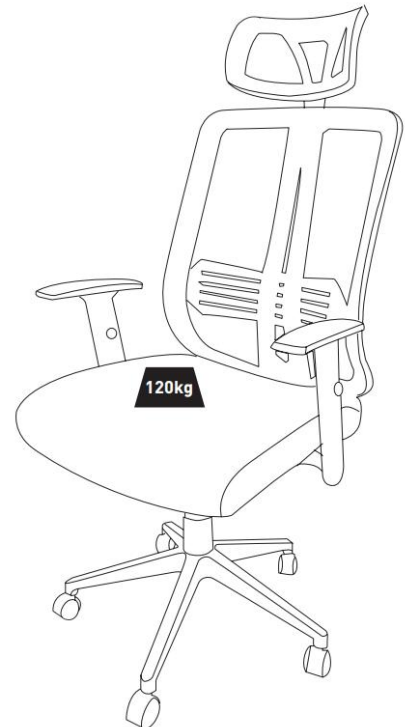

Instructions: To raise armrest, press and hold button on the outside of the armrest and pull up to your desired height. Release the button and the armrest will click into place. To lower armrest, press and hold button on the outside of the armrest and push down to desired height. Release the button and the armrest will click into place. **Please note: the maximum recommended weight for this chair is 120kg.**



**ASSEMBLY IS COMPLETE**

# CARE AND MAINTENANCE

## **REGULAR CARE:**

- Protect from direct sunlight
- Vacuum regularly using low suction
- Rotate reversible cushions regularly
- Avoid exposure to new clothing, cushions or throws as this may lead to dye transfer and permanent staining

## **CLEANING:**

- Do not remove cushion covers for separate cleaning even though they may have zippers
- Do not wash, Do not dry clean, Do not shampoo clean
- Clean only with hot water extraction machine. Professional cleaning recommended
- Do not use dish washing liquid or laundry detergent. Use only upholstery detergents
- Do not wet filling
- Dry in shade away from direct heat and sunlight
- Allow to dry thoroughly before re-use

## **SPOT CLEANING:**

- Do not rub
- Do not spot clean with any solvent
- Treat spills and stains as soon as possible
- Gently scrape off any soil or blot any liquid from the surface of the fabric before applying cleaner
- Apply proprietary cleaning agents strictly according to instructions to remove the residue of the spill
- Do not saturate the fabric or interior with water or other cleaning liquids

## **WARNING:**

Apply only water-based soil resist (fabric protection) treatments. Do not use aerosol products

\* PILLING IS NOT A FABRIC DEFECT OR FAULT AND IS NOT COVERED BY WARRANTY

\* PILLING IS A NORMAL OCCURRENCE CAUSED BY WEAR AND TEAR AND DOES NOT AFFECT THE DURABILITY OR FUNCTIONALITY OF THE FABRIC AND IS EASILY REMOVED

- **Do not:**
  - Use this product as a step stool or ladder
  - Failure to follow this warning could result in injury